



Colombia C&I PV+BESS Solution

**哥伦比亚工商业光储解决方案**

(Full Edition – 2025 Version)

(2025 全版)

## Preface

### 前言

The Colombian C&I solar and energy storage market is entering a rapid growth phase driven by national policies, tariff structures, and the increasing need for grid resilience. LIVOLTEK, a Hexing Group company, brings a decade of power electronics, grid automation, and digital energy experience to create a unified, end-to-end PV+BESS solution tailored for Colombia's distribution companies (Enel, EPM, Celsia, Air-e, Afinia) and EPC partners.

哥伦比亚工商业光储市场正在进入高速发展阶段，国家政策、电价结构、弱电网需求等共同推动企业对光伏与储能的强烈需求。LIVOLTEK（海兴集团旗下企业）依托在电力电子、配网自动化与数字能源领域的深厚积累，为哥伦比亚的配电公司（Enel、EPM、Celsia、Air-e、Afinia）以及本地 EPC 合作伙伴打造一套标准化、端到端的光储解决方案。

This document integrates market analysis, digital ecosystem architecture (PowerPuls, PowerNest, PowerSync, PowerHive, EnergyOrbit), engineering design, financial modeling, technical SLDs, and risk control frameworks into a complete system. It is structured for decision-makers, utilities, EPC partners, engineering consultants, and investors.

本文件整合了市场分析、数字能源生态体系（PowerPuls、PowerNest、PowerSync、PowerHive、EnergyOrbit）、工程设计、财务模型、技术 SLD、风险控制框架等内容，形成一套面向决策者、配电公司、EPC 合作伙伴、工程顾问及投资方的完整体系。

# 目 录

<b>Chapter 1 — Colombia Energy Transition Overview .....</b>	<b>1</b>
<b>第 1 章 —— 哥伦比亚能源转型概述 .....</b>	<b>1</b>
1.1 National Energy Policy Summary .....	1
1.1 国家能源政策概述 .....	1
1.2 Law 1715 – FNCER Framework .....	2
1.2 1715 号法 —— FNCER 框架 .....	2
1.3 Distributed Energy Deployment Trends .....	2
1.3 分布式能源发展趋势 .....	2
1.4 Implications for C&I PV+BESS .....	3
1.4 对工商业光储的意义 .....	3
<b>Chapter 2 — Regulatory, Tariff &amp; Utility Landscape .....</b>	<b>4</b>
<b>第 2 章 —— 法规、电价与配电格局 .....</b>	<b>4</b>
2.1 CREG Tariff Structure .....	4
2.1 CREG 电价结构 .....	4
2.2 Distribution Utility Landscape .....	4
2.2 配电公司格局 .....	4
2.3 ZNI (Non-Interconnected Zones) .....	5
2.3 ZNI 非互联区 .....	5
2.4 Tariff Drivers for PV+BESS Adoption .....	5
2.4 电价驱动因素 .....	5

<b>Chapter 3 — Market Landscape &amp; Opportunity Mapping</b> .....	<b>7</b>
<b>第 3 章 —— 市场格局与机会映射</b> .....	<b>7</b>
3.1 Market Logic: Policy × Utility × Tariff.....	7
3.1 市场逻辑：政策 × 配电公司 × 电价结构.....	7
3.2 Opportunity Matrix (Utility × Scenario).....	7
3.2 机会矩阵（配电公司 × 场景）.....	7
3.3 Detailed Regional Opportunity Analysis.....	7
3.3 区域机会拆解.....	7
3.4 Updated Illustration 3-4 — LIVOLTEK Digital Ecosystem Market-Fit Map.....	8
3.4 更新版图 3-4 —— LIVOLTEK 数字能源生态与市场需求匹配图.....	8
<b>Chapter 4 — LIVOLTEK Digital Energy Ecosystem</b> .....	<b>9</b>
<b>第 4 章 —— LIVOLTEK 数字能源生态系统</b> .....	<b>9</b>
4.1 Ecosystem Overview.....	9
4.1 生态系统总览.....	9
4.2 Product Portfolio Overview.....	9
4.2 产品全景简介.....	9
4.2.1 PowerPuls — High-Speed Edge Measurement Module.....	9
4.2.1 PowerPuls —— 毫秒级边缘量测模组.....	9
4.2.2 PowerScope — Site-Level Energy Flow Analyzer.....	10
4.2.2 PowerScope —— 站级能源流分析仪.....	10
4.2.3 PowerNest — PV+BESS Integrated Controller.....	10
4.2.3 PowerNest —— 光储一体化控制器.....	10
4.2.4 PowerSync — PCS Cluster Controller.....	11
4.2.4 PowerSync —— PCS 集群控制器.....	11

4.2.5 PowerHub — EV+PV+BESS Hybrid Energy Hub Controller.....	11
4.2.5 PowerHub —— 充储光一体能源枢纽控制器.....	11
4.2.6 PowerHive — Campus & Industrial Park EMS.....	12
4.2.6 PowerHive —— 园区级能源管理系统.....	12
4.2.7 EnergyOrbit — Cloud Energy & Carbon Platform.....	12
4.2.7 EnergyOrbit —— 云端能源与碳排平台.....	12
4.3 System Architecture (Five-Layer Model).....	13
4.3 系统架构（五层模型）.....	13
4.4 How the Ecosystem Enables Colombian Use Cases.....	13
4.4 生态系统如何支撑哥伦比亚的所有场景.....	13
<b>Chapter 5 — Standardized C&amp;I PV+BESS Solutions for Colombia.....</b>	<b>15</b>
<b>第 5 章 —— 哥伦比亚工商业光储标准化解决方案.....</b>	<b>15</b>
5.1 Solution Overview.....	15
5.1 解决方案概述.....	15
5.2 Solution Type 1: Stable Grid C&I PV+BESS.....	15
5.2 场景一：稳定电网工商业光储方案.....	15
5.2.1 Value Proposition.....	16
5.2.1 价值主张.....	16
5.2.2 System Architecture & SLD.....	16
5.2.2 系统架构与单线图（占位）.....	16
5.2.3 Recommended Configuration.....	17
5.2.3 推荐配置.....	17
5.2.4 Control Strategy.....	18

5.2.4 控制策略.....	18
5.3 Solution Type 2: Weak Grid PV+BESS (GFM Enabled).....	18
5.3 场景二: 弱电网 GFM 型光储方案.....	18
5.3.1 Value Proposition .....	18
5.3.1 价值主张.....	18
5.3.2 System Architecture & SLD .....	19
5.3.2 系统架构与单线图.....	19
5.3.3 Recommended Configuration.....	20
5.3.3 推荐配置.....	20
5.3.4 Control Strategy .....	21
5.3.4 控制策略.....	21
5.4 Solution Type 3: Off-grid / Hybrid Microgrid.....	21
5.4 场景三: 离网 / 光储柴混合微电网.....	21
5.4.1 Value Proposition .....	21
5.4.1 价值主张.....	21
5.4.2 System Architecture & SLD .....	22
5.4.2 系统架构与单线图.....	22
5.4.3 Recommended Configuration.....	23
5.4.3 推荐配置.....	23
5.4.4 Control Strategy .....	24
5.4.4 控制策略.....	24
5.5 Solution Comparison Table .....	24
5.5 三类方案对比表.....	24

5.6 Integration with LIVOLTEK Digital Ecosystem .....	24
5.6 与 LIVOLTEK 数字生态的集成 .....	24
<b>Chapter 6 — Technical Specifications &amp; SLD Designs .....</b>	<b>26</b>
<b>第 6 章 —— 技术规格与单线图设计 .....</b>	<b>26</b>
6.1 General Engineering Principles .....	26
6.1 通用工程设计原则 .....	26
6.2 Standard SLD Type 1 — Stable Grid C&I PV+BESS .....	26
6.2 稳定电网标准单线图 (SLD 类型 1) .....	26
6.2.1 Applicable Regions .....	26
6.2.1 适用区域 .....	26
6.2.2 ASCII SLD (Engineering Placeholder) .....	27
6.2.2 ASCII 单线图 (工程占位版) .....	27
6.2.3 Technical Specifications .....	27
6.2.3 技术规格 .....	27
6.3 Standard SLD Type 2 — Weak Grid PV+BESS (GFM Enabled) .....	28
6.3 弱电网标准单线图 (SLD 类型 2, 支持 GFM) .....	28
6.3.1 Applicable Regions .....	28
6.3.1 适用区域 .....	28
6.3.2 ASCII SLD (Engineering Placeholder) .....	29
6.3.2 ASCII 单线图 (工程占位版) .....	29
6.3.3 Technical Specifications .....	30
6.3.3 技术规格 .....	30
6.4 Standard SLD Type 3 — Off-grid / Hybrid Microgrid (ZNI) .....	30
6.4 离网/混合微电网标准单线图 (SLD 类型 3) .....	30

6.4.1 Applicable Regions .....	30
6.4.1 适用区域 .....	30
6.4.2 ASCII SLD (Engineering Placeholder) .....	31
6.4.2 ASCII 单线图 (工程占位版) .....	31
6.4.3 Technical Specifications .....	32
6.4.3 技术规格 .....	32
6.5 Protection Settings (RETIE + IEEE 1547) .....	32
6.5 并网保护定值 (RETIE + IEEE 1547) .....	32
6.5.1 Standard Protection Table .....	32
6.5.1 标准保护定值表 .....	32
6.6 SCADA & EMS Point Lists .....	33
6.6 SCADA / EMS 点表模板 .....	33
6.6.1 PCS Point List .....	33
6.6.1 PCS 点表 .....	33
6.7 Communication Architecture .....	33
6.7 通信架构 .....	33
6.8 Typical BOM (Bill of Materials) .....	34
6.8 典型 BOM (物料清单) .....	34
<b>Chapter 7 — Financial Modeling &amp; IRR Analysis .....</b>	<b>35</b>
<b>第 7 章 —— 财务模型与 IRR 分析 .....</b>	<b>35</b>
7.1 CREG Tariff Structure and PV+BESS Drivers .....	35
7.1 CREG 电价结构与光储经济性驱动因素 .....	35
7.2 CAPEX Structure .....	35
7.2 CAPEX 成本结构 .....	35

7.3 OPEX Breakdown .....	36
7.3 OPEX 成本结构 .....	36
7.4 Revenue Streams for PV+BESS .....	36
7.4 光储的收益来源 .....	36
7.5 Baseline IRR Model Example .....	36
7.5 基准 IRR 模型示例 .....	36
7.6 IRR by Scenario .....	37
7.6 各场景的 IRR 范围 .....	37
7.7 Sensitivity Analysis .....	37
7.7 敏感性分析 .....	37
7.8 Business Models .....	38
7.8 商业模式 .....	38
7.9 Summary .....	38
7.9 小结 .....	38
<b>Chapter 8 — Implementation Roadmap &amp; EPC Workflow .....</b>	<b>39</b>
<b>第 8 章 —— 项目实施路线图与 EPC 交付流程 .....</b>	<b>39</b>
8.1 Project Lifecycle Overview .....	39
8.1 项目生命周期总览 .....	39
8.2 Phase 1: Site Survey & Load Study .....	39
8.2 阶段一：现场勘查与负荷研究 .....	39
8.3 Phase 2: Feasibility & ROI Analysis .....	40
8.3 阶段二：可行性研究与 IRR 测算 .....	40
8.4 Phase 3: Preliminary Engineering (PE) .....	40
8.4 阶段三：初步工程设计 (PE) .....	40

8.5 Phase 4: Permitting & RETIE/CREG Filings .....	41
8.5 阶段四: 许可与 RETIE/CREG 报批 .....	41
8.6 Phase 5: Detailed Engineering (DE) .....	41
8.6 阶段五: 施工图设计 (DE) .....	41
8.7 Phase 6 — Procurement & FAT .....	42
8.7 阶段六 —— 采购与工厂验收 (FAT) .....	42
8.8 Phase 7: Construction & Installation .....	42
8.8 阶段七: 施工与安装 .....	42
8.9 Phase 8: Commissioning & SAT .....	43
8.9 阶段八: 调试与现场验收 (SAT) .....	43
8.10 Phase 9: Utility Interconnection .....	43
8.10 阶段九: 配电公司并网 .....	43
8.11 Phase 10: O&M & Digital Monitoring (EnergyOrbit) .....	43
8.11 阶段十: 运维与数字化监控 (EnergyOrbit) .....	43
8.12 Implementation Timeline .....	44
8.12 项目实施周期 .....	44
8.13 Summary .....	44
8.13 小结 .....	44
<b>Chapter 9 — Risk Assessment &amp; Mitigation Plan .....</b>	<b>45</b>
<b>第 9 章 —— 风险评估与缓解方案 .....</b>	<b>45</b>
9.1 Overview of Risk Categories .....	45
9.1 风险类别总览 .....	45
9.2 Regulatory & Interconnection Risks .....	45
9.2 法规与并网风险 .....	45

9.3 Grid & Technical Risks .....	46
9.3 电网与技术风险 .....	46
9.4 Construction & EPC Execution Risks .....	47
9.4 施工与 EPC 执行风险 .....	47
9.5 Financial & Tariff Risks .....	48
9.5 财务与电价风险 .....	48
9.6 Environmental & Climate Risks .....	48
9.6 环境与气候风险 .....	48
9.7 O&M & Lifecycle Risks .....	49
9.7 运维与全生命周期风险 .....	49
9.8 Risk Matrix Summary .....	49
9.8 风险矩阵总结 .....	49
9.9 Summary .....	50
9.9 小结 .....	50
<b>Chapter 10 — Appendices (Technical Annex) .....</b>	<b>51</b>
<b>第 10 章 —— 附录 (技术附件) .....</b>	<b>51</b>
10.1 Technical Datasheet Summaries .....	51
10.1 技术规格书摘要 .....	51
10.1.1 BESS Cabinet (125 kW / 261 kWh) — Datasheet .....	51
10.1.1 柜式储能 (125kW / 261kWh) —— 技术规格 .....	51
10.1.2 PowerNest — PV+BESS Integrated Controller .....	51
10.1.2 PowerNest —— 光储一体化控制器 .....	51
10.1.3 PowerSync — PCS Cluster Controller .....	51
10.1.3 PowerSync —— PCS 集群控制器 .....	51

10.1.4 PowerPuls — High-speed Measurement Module .....	52
10.1.4 PowerPuls —— 毫秒级量测模组 .....	52
10.1.5 PowerHive & EnergyOrbit .....	52
10.1.5 PowerHive 与 EnergyOrbit .....	52
10.2 Standard SLDs .....	52
10.2 标准单线图 .....	52
10.2.1 SLD Type A — Stable Grid .....	52
10.2.2 SLD Type B — Weak Grid (GFM) .....	52
10.2.3 SLD Type C — Off-grid Hybrid Microgrid .....	52
10.3 Protection Setting Template .....	53
10.3 并网保护定值模板 .....	53
10.4 SCADA / EMS Point List Templates .....	53
10.4 SCADA / EMS 点表模板 .....	53
10.5 Communication Architecture Diagram .....	53
10.5 通信架构 .....	53
10.6 Typical BOM (Bill of Materials) .....	53
10.6 典型物料清单 .....	53
10.7 SAT & Commissioning Checklists .....	54
10.7 SAT & 调试清单 .....	54
10.8 O&M Templates .....	54
10.8 运维模板 .....	54
10.9 Compliance Matrix .....	55
10.9 合规性矩阵 .....	55
10.10 Deliverable Package List .....	55

10.10 最终交付文件清单 ..... 55

## Chapter 1 — Colombia Energy Transition Overview

### 第 1 章 —— 哥伦比亚能源转型概述

#### 1.1 National Energy Policy Summary

##### 1.1 国家能源政策概述

Colombia has committed to one of the most ambitious clean-energy transitions in Latin America, powered by strong government policies, multi-decade electrification targets, and a rapidly expanding FNCER (Non-Conventional Renewable Energy Sources) regulatory framework.

哥伦比亚是拉丁美洲能源转型最积极的国家之一，其能源政策明确推动清洁能源、电气化和非常规可再生能源（FNCER）的快速发展。

##### Key elements include:

##### 核心政策包括：

- Law 1715 (2014) – foundational law enabling renewable energy and distributed generation.
- 1715 号法（2014）——确立可再生能源与分布式发电法律基础。
- Law 2099 (2021) – expands incentives and modernizes the energy transition framework.
- 2099 号法（2021）——强化能源转型的激励与监管机制。
- Subsidies and tax incentives – VAT exemption, accelerated depreciation, import tax relief.
- 税收激励——增值税免除、加速折旧、进口税豁免。
- ZNI electrification strategy – rural/off-grid electrification via solar + BESS microgrids.
- ZNI 电气化战略——推动偏远地区通过“光伏+储能”实现可靠供电。

These policies make C&I PV+BESS a national priority across both urban and rural regions. 这些政策使工商业光储成为全国范围内的重点发展方向，包括城市和偏远地区。

## 1.2 Law 1715 – FNCER Framework

### 1.2 1715 号法 —— FNCER 框架

Law 1715 established the legal foundation for renewable energy participation in the electricity market, distributed generation, and investment incentives.

1715 号法为可再生能源并网、分布式发电以及投资激励建立了法律基础。

#### Key provisions:

##### 主要条款:

- Enables self-generation ( “autogeneración” ) for industrial and commercial users.
- 允许工商业用户 “自主发电” 。
- Enables surplus electricity injection into the grid (subject to utility approval).
- 允许富余电量上网 (需供电公司批准)。
- Guarantees access to the distribution network for qualified FNCER systems.
- 保证合规光伏系统获得配电网接入资格。
- Tax benefits / 税收优惠:
  - 50% income tax deduction / 所得税抵扣 (50%)
  - 5-year accelerated depreciation / 5 年加速折旧
  - VAT exemption / 增值税免除
  - Import duty exemption / 进口税免除

## 1.3 Distributed Energy Deployment Trends

### 1.3 分布式能源发展趋势

C&I customers—especially manufacturing, logistics, data centers, retail, and hospitality—are now the strongest drivers of distributed solar + BESS deployment.

工商业用户——尤其是制造业、物流中心、数据中心、零售和酒店业——已成为分布式光储部署的最强推动力量。

#### Trends:

### 趋势:

- Rapid growth of rooftop solar in Bogotá and Medellín
- 波哥大与麦德林屋顶光伏快速增长
- Increasing adoption of BESS due to high tariffs
- 因高电价导致储能采用率提升
- Weak-grid Caribbean regions adopting PV+BESS for PQ + backup
- 加勒比地区弱电网用户采用光储提升 PQ 与备电能力
- ZNI communities shifting away from diesel
- ZNI 区域逐步替代柴油发电

## 1.4 Implications for C&I PV+BESS

### 1.4 对工商业光储的意义

Colombia' s energy transition directly accelerates C&I PV+BESS adoption across three fronts:

哥伦比亚的能源转型为工商业光储带来三重推动:

1. Economics — high tariffs → strong ROI / 经济性——高电价 → 强 IRR
2. Reliability — grid instability → BESS for PQ/backup / 可靠性——弱电网 → 储能用于 PQ/ 备电
3. Policy — tax incentives + simplified interconnection / 政策——税收激励 + 并网机制不断优化

## Chapter 2 — Regulatory, Tariff & Utility Landscape

### 第 2 章 —— 法规、电价与配电格局

#### 2.1 CREG Tariff Structure

#### 2.1 CREG 电价结构

CREG regulates electricity pricing and defines a standardized tariff model consisting of:

CREG 通过统一公式监管电价，主要由以下组件组成：

G: Generation (发电)

T: Transmission (输电)

D: Distribution (配电)

C: Commercialization (商业化)

PR: Regulated losses (损耗)

R: Restrictions/charges (约束与附加费)

For C&I users, high marginal tariffs and demand charges create strong incentives for PV+BESS deployment.

工商业用户的边际电价与需量费用较高，使得光储的经济性极具吸引力。

#### 2.2 Distribution Utility Landscape

#### 2.2 配电公司格局

Colombia' s distribution network is operated by five major utilities:

哥伦比亚配电网由五大主要运营商管理：

1. Enel Colombia (Bogotá + Cundinamarca)
2. EPM (Medellín + Antioquia)
3. Celsia/EPISA (Valle del Cauca, Tolima)

4. Air-e (Atlántico, Magdalena, La Guajira)
5. Afinia (EPM Group) (Bolívar, Sucre, Córdoba, Cesar)

Each region has different grid conditions, loss levels, and tariff structures—making PV+BESS opportunities highly localized.

各区域电网情况、电价与损耗水平差异显著，导致光储机会具有很强的地域特性。

## 2.3 ZNI (Non-Interconnected Zones)

### 2.3 ZNI 非互联区

- Cover 52% of the country' s land area / 仅占全国土地面积的 52%
- Serve rural communities, islands, and jungle regions / 服务农村、岛屿与丛林地带
- Power supply dominated by diesel / 主供电方式为柴油
- The government targets solar+BESS microgrids as the main replacement / 政府推动光储微电网替代柴油
- ZNI areas are the strongest IRR opportunities for hybrid microgrids. / ZNI 是光储柴微电网最具经济性的区域。

## 2.4 Tariff Drivers for PV+BESS Adoption

### 2.4 电价驱动因素

**C&I users face / 工商业用户普遍面临：**

- High energy charges (高能量电价)
- High demand charges (高需量费用)
- TOU differentials (峰谷价差)
- Weak-grid outages (弱网停电)
- PQ problems (PQ 问题)

**These create strong drivers for / 促使以下需求快速增长：**

- PV 供电成本替代
- 储能削峰

- PQ 改善
- 备用电源
- 光储一体化方案

## Chapter 3 — Market Landscape & Opportunity Mapping

### 第 3 章 —— 市场格局与机会映射

#### 3.1 Market Logic: Policy × Utility × Tariff

#### 3.1 市场逻辑：政策 × 配电公司 × 电价结构

Colombia’s PV+BESS opportunities must be understood at the intersection of:

哥伦比亚光储市场必须从以下三维度交叉分析：

1. National policy – incentives, interconnection / 配电公司 – 电网状况与损耗
2. Tariff structure – 电价与需量费

This forms a holistic “opportunity blueprint” for every region.

三者共同构成每个区域的机会蓝图。

#### 3.2 Opportunity Matrix (Utility × Scenario)

#### 3.2 机会矩阵（配电公司 × 场景）

Utility	Stable Grid	Weak Grid	High Tariff	ZNI	Best Scenario
Enel	●●●●	●●	●●●	–	C&I PV+BESS
EPM	●●●●	●●●	●●●	–	Industrial Microgrid
Celsia	●●●●	●●	●●●	–	Utility PV+BESS
Air-e	●●	●●●●	●●●●	●●	PQ + Backup + Peak Shaving
Afinia	●●●	●●●	●●●	●	Industrial/Hybrid
ZNI	–	–	–	●●●●	Hybrid Solar+BESS+Diesel

（“●” 越多表示机会越强）

#### 3.3 Detailed Regional Opportunity Analysis

#### 3.3 区域机会拆解

Enel Bogotá → 最适合 C&I 光储（高密度商业与工业）

EPM Medellín → 工业园区微电网需求强

Celsia → 电站级光储与大型园区

Air-e → 弱网、停电、损耗 → 光储 PQ 支撑

Afinia → 加勒比次发达区域 → 工商业光储可快速落地

ZNI → 光储柴微电网最佳 IRR

### 3.4 LIVOLTEK Digital Ecosystem Market-Fit Map

#### 3.4 LIVOLTEK 数字能源生态与市场需求

1. High C&I tariffs → EnergyOrbit + PowerHive / 工商业高电价 → EnergyOrbit + PowerHive
2. Weak-grid instability → PowerSync + GFM PCS / 弱电网不稳定 → PowerSync + GFM PCS
3. Zero-export enforcement → PowerPuls + PowerNest / 严格的零逆流要求 → PowerPuls + PowerNest
4. Feeder losses (Air-e/Afinia) → PowerPuls + Smart Grid Devices / 配网高损耗 (Air-e/Afinia) → PowerPuls + 配网自动化设备
5. ZNI electrification → PowerNest + BESS Hybrid Microgrids / ZNI 偏远供电 → PowerNest + 光储柴混合微电网

#### Ecosystem Layers / 生态体系层级:

- Measurement: PowerPuls / 量测层: PowerPuls
- Local Control: PowerNest, PowerHub / 本地控制层: PowerNest、PowerHub
- Coordination: PowerSync / 协同层: PowerSync
- EMS: PowerHive / 站点/园区层: PowerHive
- Cloud: EnergyOrbit / 云端智能层: EnergyOrbit
- Hardware: BESS + RMU/FTU/DTU / 硬件基础层: BESS + RMU/FTU/DTU

## Chapter 4 — LIVOLTEK Digital Energy Ecosystem

### 第 4 章 —— LIVOLTEK 数字能源生态系统

#### 4.1 Ecosystem Overview

##### 4.1 生态系统总览

The LIVOLTEK Digital Energy Ecosystem integrates measurement, control, coordination, EMS optimization, and cloud intelligence to support PV, BESS, EV charging, microgrids, and distribution-grid applications. It is designed to meet the diverse needs of Colombia's C&I market, weak-grid coastal regions, and ZNI microgrids.

LIVOLTEK 数字能源生态系统整合量测、控制、协同、EMS 优化与云端智能能力，全面支持光伏、储能、充电、微电网及配网场景，能够精准匹配哥伦比亚工商业市场、弱电网沿海区域及 ZNI 微电网的多样需求。

##### **The ecosystem consists of six functional layers / 生态体系由六个功能层构成：**

1. Measurement Layer (量测层): PowerPuls、PowerScope、Smart Meters
2. Local Control Layer (本地控制层): PowerNest、PowerHub
3. Coordination Layer (协同层): PowerSync
4. EMS Layer (站点/园区层): PowerHive
5. Cloud Intelligence Layer (云端智能): EnergyOrbit
6. Hardware Base Layer (硬件层): BESS、Switchgear (FTU/DTU/RMU)

#### 4.2 Product Portfolio Overview

##### 4.2 产品全景简介

###### 4.2.1 PowerPuls — High-Speed Edge Measurement Module

###### 4.2.1 PowerPuls —— 毫秒级边缘量测模组

PowerPuls is a high-speed measurement module that samples real-time power, voltage, and

current data at millisecond-level intervals. It is the key enabler of zero-export control, anti-backflow protection, PQ monitoring, and precision feeder management.

PowerPuls 是毫秒级高速量测模组，可实时采集功率、电压、电流等数据，是零逆流控制、反向功率保护、PQ 监测和精确馈线管理的重要基础能力。

**Value / 价值点:**

- Zero-export with <100ms response / 零逆流响应 <100ms
- Real-time PQ visibility / PQ 实时可视化
- Essential for weak-grid regions / 弱电网场景关键能力

#### **4.2.2 PowerScope — Site-Level Energy Flow Analyzer**

##### **4.2.2 PowerScope —— 站级能源流分析仪**

PowerScope provides deep energy-flow visibility across PV, BESS, EV chargers, diesel generators, and critical loads.

PowerScope 可对光伏、储能、充电桩、柴油机与关键负荷进行全能流可视化。

**Value / 价值点:**

- High-resolution load analysis / 高分辨负荷分析
- Identifies optimization opportunities / 精准识别优化点
- Foundation for proper sizing / 科学选型依据

#### **4.2.3 PowerNest — PV+BESS Integrated Controller**

##### **4.2.3 PowerNest —— 光储一体化控制器**

PowerNest orchestrates PV, PCS, batteries, meters, CT/VT, and load controllers. It enables real-time power control, zero-export enforcement, peak shaving, and fast grid-off transitions.

PowerNest 负责光伏、PCS、电池、计量装置及负荷控制的统一管理，实现实时功率控制、零逆流、

削峰和快速离网等功能。

**Value / 价值点:**

- Seamless PV+BESS integration / 光储一体式控制
- Fast dynamic response / 高速响应
- Zero-export + PQ stabilization / 零逆流 + PQ 稳定

#### **4.2.4 PowerSync — PCS Cluster Controller**

##### **4.2.4 PowerSync —— PCS 集群控制器**

PowerSync coordinates multi-PCS clusters at both cabinet scale (125kW) and container scale (5MWh). It provides GFM/GFL switching, black-start, ramp-rate control, and PQ optimization.

PowerSync 可管理机柜级 (125kW) 与集装箱级 (5MWh) 多 PCS 集群, 支持 GFM/GFL 切换、黑启动、爬坡率控制与 PQ 优化。

**Value / 价值点:**

- Turns multiple PCS into a single stable power source / 多 PCS 变成 “一个电源”
- Enables weak-grid support / 弱网支撑能力强
- Required for all large systems / 大容量光储必备

#### **4.2.5 PowerHub — EV+PV+BESS Hybrid Energy Hub Controller**

##### **4.2.5 PowerHub —— 充储光一体能源枢纽控制器**

PowerHub integrates EV fast chargers, PV, and BESS, optimizing charging curves, reducing demand peaks, and ensuring continuous uptime.

PowerHub 将快充、光伏与储能整合为一体, 优化充电曲线、降低需量峰值并确保高可用性。

**Value / 价值点:**

- Enables grid-friendly fast charging / 友好型快充
- Reduces station OPEX / 降低充电站运营成本

- Supports TOU optimization / 支持分时优化

## 4.2.6 PowerHive — Campus & Industrial Park EMS

### 4.2.6 PowerHive —— 园区级能源管理系统

PowerHive coordinates multi-building energy assets in industrial/commercial parks, providing optimal dispatch of PV, BESS, HVAC, EV charging, and critical loads.

PowerHive 用于工业园区和商业园区，实现光伏、储能、空调、充电桩和关键负荷的能量调度。

#### Value / 价值点:

- Multi-building optimization / 园区级协同优化
- Cost reduction for whole campus / 降低全园区能源成本
- Centralized control + local autonomy / 集中管理 + 本地自治

## 4.2.7 EnergyOrbit — Cloud Energy & Carbon Platform

### 4.2.7 EnergyOrbit —— 云端能源与碳排平台

EnergyOrbit aggregates real-time data from all site assets and provides carbon accounting, fleet optimization, fault prediction, and performance dashboards.

EnergyOrbit 汇集各站点的数据，实现碳排核算、集群优化、故障预测及性能看板分析。

#### Value / 价值点:

- Fleet-wide visibility / 集群可视化
- Predictive O&M / 预测性运维
- Automated reporting (CREG/ISO/EPC clients) / 自动化报表 (CREG/ISO/大客户)

## 4.3 System Architecture (Five-Layer Model)

### 4.3 系统架构 (五层模型)

Layer 1: Measurement – PowerPuls / PowerScope / Smart Meters

第一层：量测层

Layer 2: Local Control – PowerNest / PowerHub

第二层：本地控制层

Layer 3: Coordination – PowerSync

第三层：协同控制层

Layer 4: EMS – PowerHive

第四层：站点/园区 EMS 层

Layer 5: Cloud – EnergyOrbit

第五层：云端智能层

Layer 6: Hardware Base – BESS, RMU, Recloser, FTU/DTU

第六层：硬件基础层

## 4.4 How the Ecosystem Enables Colombian Use Cases

### 4.4 生态系统如何支撑哥伦比亚的所有场景

#### 1) Stable Grid Cities (Bogotá, Medellín) / 稳定电网城市 (波哥大、麦德林)

- Peak shaving / 削峰
- TOU optimization / 分时优化
- Zero-export / 零逆流控制

#### 2) Weak Grid Coastal Regions (Air-e, Afinia) / 弱电网沿海 (Air-e、Afinia)

- GFM stabilization / GFM 稳压

- Anti-tripping / 防脱网
- PQ improvement / PQ 改善

### 3) ZNI Microgrids / ZNI 微电网

- PV+BESS+Diesel coordination / 光储柴协调控制
- 24/7 energy / 提供 24/7 能源保障
- Reduced diesel cost by 50–80% / 柴油成本下降 50–80%

## Chapter 5 — Standardized C&I PV+BESS Solutions for Colombia

### 第 5 章 —— 哥伦比亚工商业光储标准化解决方案

#### 5.1 Solution Overview

##### 5.1 解决方案概述

Colombia's C&I users operate under three distinct grid conditions—stable urban grids, weak grid coastal regions, and fully off-grid ZNI communities. LIVOLTEK provides three standardized PV+BESS solution archetypes that match these conditions.

哥伦比亚的工商业用户面临三类典型电网条件：城市稳定电网、加勒比沿海弱电网、ZNI 完全离网区域。LIVOLTEK 为这三类场景提供量身定制的三种标准化光储解决方案。

##### Three archetypes:

##### 三大场景类型：

- Stable Grid C&I PV+BESS (稳定电网工商业光储)
- Weak Grid PV+BESS with GFM (弱电网 GFM 成网型光储)
- Off-grid / Hybrid Microgrid (离网 / 光储柴混合微电网)

#### 5.2 Solution Type 1: Stable Grid C&I PV+BESS

##### 5.2 场景一：稳定电网工商业光储方案

##### Applies to / 适用场景

- Bogotá (Enel) / 波哥大 (Enel)
- Medellín (EPM) / 麦德林 (EPM)
- Valle del Cauca (Celsia) / 考卡山谷 (Celsia)

##### Typical Users / 典型用户：

- Shopping malls 商场

- Office buildings 办公楼
- Logistics parks 物流园区
- Data centers 数据中心
- Retail chains 零售连锁

## 5.2.1 Value Proposition

### 5.2.1 价值主张

This is an economics-driven model focusing on PV self-consumption, peak shaving, TOU arbitrage, and backup for critical loads.

此方案以经济性为核心，包括自发自用、削峰、分时套利和关键负荷备电。

#### Value Points / 价值点:

- Reduce electricity bill by 15–35% / 降低电费 15–35%
- Reduce peak demand charges / 降低需量费
- Improve power quality / 提升 PQ
- Fast backup during outages / 停电期间提供快速备电

## 5.2.2 System Architecture & SLD

### 5.2.2 系统架构与单线图

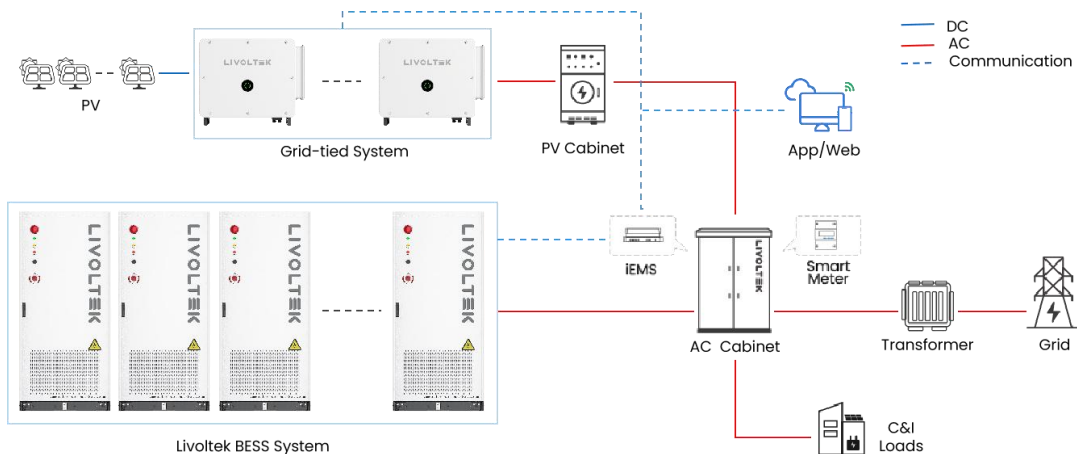

System Architecture / 系统架构图

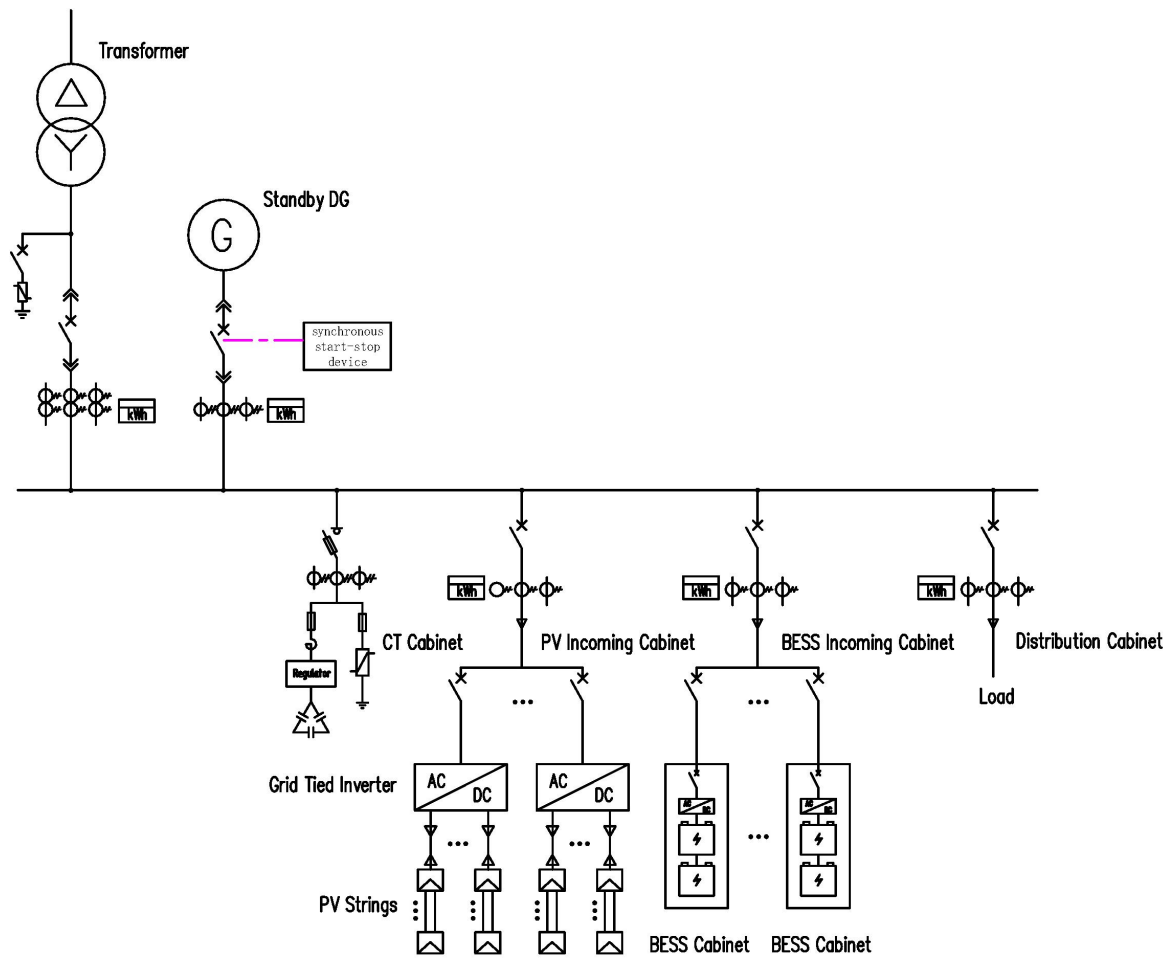

SLD / 单线图

### 5.2.3 Recommended Configuration

#### 5.2.3 推荐配置

Component	Recommendation	中文说明
PV Capacity	0.5–1.2 × peak load	光伏推荐容量：峰值负荷的 0.5–1.2 倍
BESS Capacity	1–2 hr (261 kWh typical)	储能：1–2 小时 (261 kWh 常用)
PCS Mode	GFL mode + Zero Export	PCS: GFL 模式 + 零逆流
Backup Loads	20–40% of total	备电比例：总负荷的 20–40%

## 5.2.4 Control Strategy

### 5.2.4 控制策略

#### Daytime / 白天:

PV → Load → Charge BESS (with zero-export constraint) / 光伏优先供负荷, 多余电量充储能 (零逆流控制)

#### Evening peak / 傍晚峰值:

BESS discharge → reduce peak demand / 储能放电削峰

#### Night / 夜间:

Grid → Load, optional off-peak charging / 低电价充电或待机

## 5.3 Solution Type 2: Weak Grid PV+BESS (GFM Enabled)

### 5.3 场景二: 弱电网 GFM 型光储方案

#### Applies to / 适用区域

- Caribbean Coast: Air-e, Afinia / 加勒比沿海: Air-e、Afinia
- High-loss feeders / 高损耗台区
- Voltage instability areas / 电压不稳定区域

#### 5.3.1 Value Proposition

##### 5.3.1 价值主张

The main objective is to stabilize the local bus, support PQ, prevent PV tripping, and ensure continuous power under outages.

此方案强调母线稳定、PQ 提升、防止光伏脱网, 并在停电时保持持续供电。

#### Key value points / 价值点:

- GFM support for weak grid / GFM 成网支撑弱电网
- PQ stabilization / PQ 电能质量改善

- 0-ms transition to off-grid / 0 毫秒并离网切换
- Works in high-loss feeders / 适用于高损耗台区

### 5.3.2 System Architecture & SLD

#### 5.3.2 系统架构与单线图

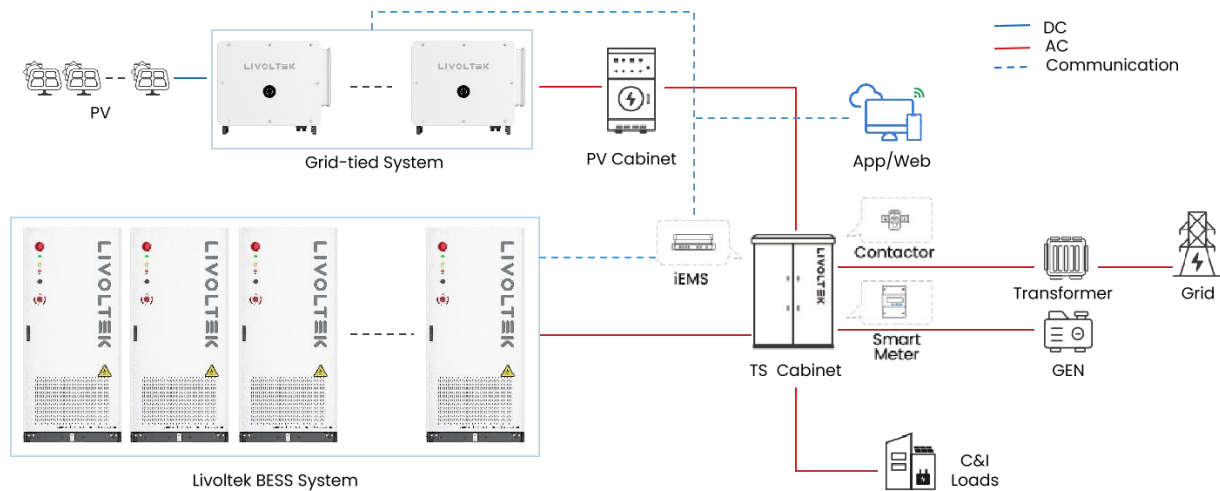

System Architecture / 系统架构图

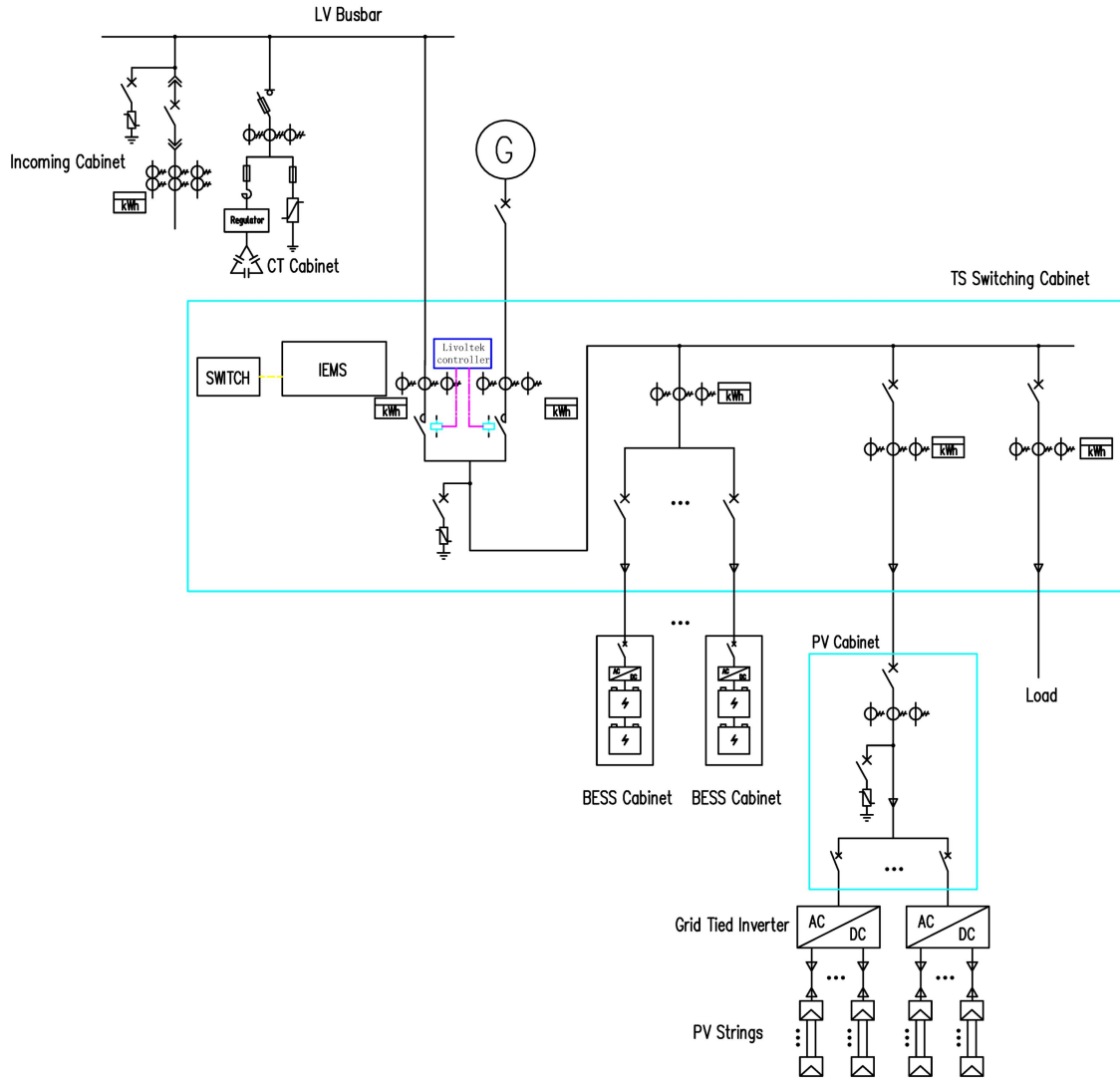

SLD / 单线图

### 5.3.3 Recommended Configuration

### 5.3.3 推荐配置

Component	Recommendation	中文说明
PCS	GFM mandatory	PCS 必须支持 GFM
BESS	1.5–3 hr	储能: 1.5–3 小时
Voltage Support	Enabled (LVVRT/HVRT)	启用 LVVRT/HVRT
Islanding	<10 ms	离网切换 <10ms

### 5.3.4 Control Strategy

#### 5.3.4 控制策略

##### Normal Grid / 正常电网:

GFL mode, PQ smoothing / GFL 模式, PQ 稳定

##### Voltage Dip / 电压跌落:

PowerSync triggers GFM stabilization / PowerSync 启动 GFM 稳压

##### Outage / 停电:

BESS instant islanding → power continues / 储能瞬时离网 → 持续供电

## 5.4 Solution Type 3: Off-grid / Hybrid Microgrid

### 5.4 场景三: 离网 / 光储柴混合微电网

#### Applies to / 适用地区

- ZNI areas (Amazon, Pacific, islands) / ZNI 区域 (亚马逊丛林、太平洋沿岸、岛屿)
- Mining sites / 矿区
- Rural villages / 农村社区

#### 5.4.1 Value Proposition

##### 5.4.1 价值主张

Hybrid microgrids reduce diesel consumption by 50–80% while providing 24/7 stable power.

混合微电网减少 50–80% 柴油消耗, 同时保证 24/7 稳定供电。

##### Value points / 价值点:

- Fuel savings / 燃油节省
- Stable 24/7 supply / 24/7 稳定供电
- Scalable modular design / 模块化扩容

### 5.4.2 System Architecture & SLD

#### 5.4.2 系统架构与单线图

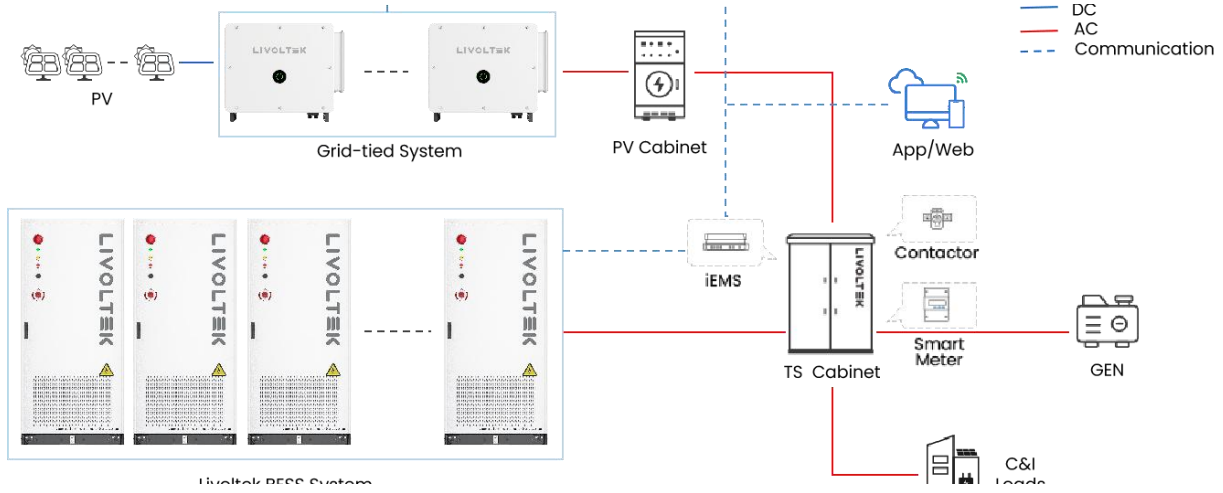

System Architecture / 系统架构图

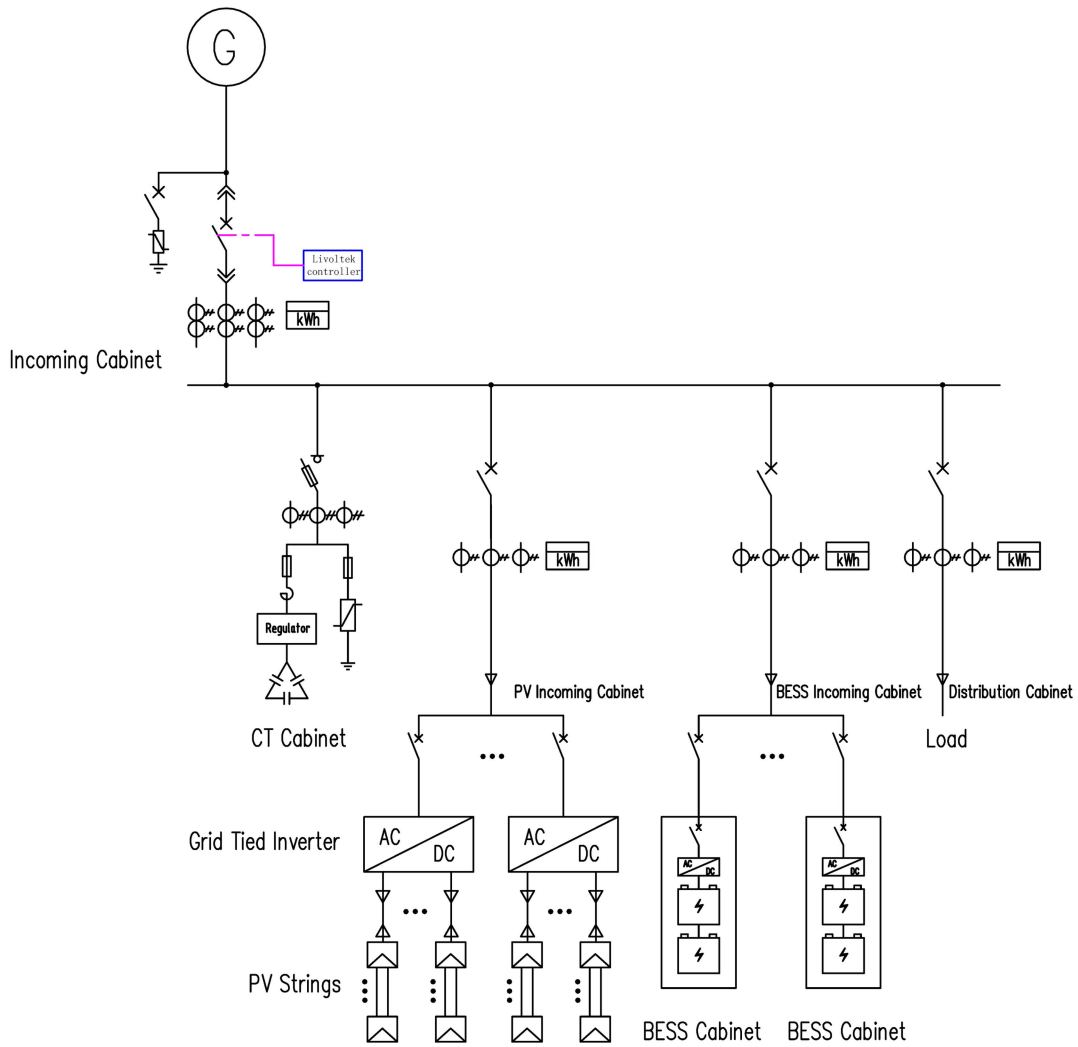

SLD / 单线图

### 5.4.3 Recommended Configuration

#### 5.4.3 推荐配置

Component	Recommendation	中文说明
PV	1.2–1.5 × peak load	光伏 1.2–1.5 倍峰值负荷
BESS	4–6 hr autonomy	储能 4–6 小时
Diesel	Emergency only	柴油仅应急

### 5.4.4 Control Strategy

#### 5.4.4 控制策略

**Daytime / 白天:**

PV → Load → Charge BESS / 光伏供电 + 储能充电

**Night / 夜间:**

BESS → Load / 储能供电

**Bad weather/ 恶劣天气:**

Diesel + BESS / 柴油辅助供电

### 5.5 Solution Comparison Table

#### 5.5 三类方案对比表

Scenario	Grid	BESS Size	Control Mode	Best Regions
Stable Grid	Strong	1–2hr	GFL + Zero Export	Bogotá / Medellín
Weak Grid	Weak	1.5–3hr	GFM/GFL Hybrid	Caribbean Coast
Off-grid	None	4–6hr	GFM Microgrid	ZNI
场景	电网条件	储能规模	控制方式	最佳区域
稳定电网	强网	1–2 小时	GFL + 零逆流	波哥大 / 麦德林
弱电网	弱网	1.5–3 小时	GFM/GFL 混合	加勒比沿海
离网微电网	无电网	4–6 小时	GFM 微电网	ZNI

### 5.6 Integration with LIVOLTEK Digital Ecosystem

#### 5.6 与 LIVOLTEK 数字生态的集成

All three solutions are powered by the same digital ecosystem:

三类方案都基于相同的数字能源生态:

- PowerPuls (毫秒级量测)
- PowerNest (光储控制)
- PowerSync (多 PCS 协同)
- PowerHive (园区 EMS)

- PowerHub (充储光控制)
- EnergyOrbit (云端智能)
- BESS Family (125kW/261kWh & 5MWh)
- Grid Automation (FTU/DTU/RMU)

This ensures scalability, reliability, and consistent operation across Colombia.

保证方案在哥伦比亚全区域可复制、可扩展且运行一致。

## Chapter 6 — Technical Specifications & SLD Designs

### 第 6 章 —— 技术规格与单线图设计

#### 6.1 General Engineering Principles

##### 6.1 通用工程设计原则

All PV+BESS systems deployed in Colombia must comply with RETIE, CREG interconnection rules, IEC standards, IEEE 1547, and utility-specific requirements (Enel, EPM, Celsia, Air-e, Afinia).

所有光储系统必须满足 RETIE、电监局 CREG 的并网标准、IEC 国际标准、IEEE 1547，以及各配电公司的要求 (Enel、EPM、Celsia、Air-e、Afinia)。

##### Core principles include / 核心原则包括:

- Safety-first (RETIE compliance for all electrical work) / 安全第一 (满足 RETIE 电气安全标准)
- Zero-export capability for urban C&I / 零逆流能力是城市工商业要求
- GFM/GFL hybrid control for weak-grid regions / GFM/GFL 混合控制适用于弱电网区域
- Seamless islanding (<10 ms for backup scenarios) / 无缝离网切换 (<10ms, 用于备电场景)
- Harmonic limits (THD < 3–5%) / 谐波控制 (THD 小于 3–5%)
- SCADA/EMS interoperability (Modbus, IEC104, MQTT) / SCADA/EMS 互联 (Modbus、IEC104、MQTT)
- Standardized SLD & protection settings for each utility / 标准化 SLD 与保护定值 满足各配电公司审核。

#### 6.2 Standard SLD Type 1 — Stable Grid C&I PV+BESS

##### 6.2 稳定电网标准单线图 (SLD 类型 1)

###### 6.2.1 Applicable Regions

###### 6.2.1 适用区域

- Bogotá (Enel)
- Medellín (EPM)
- Valle del Cauca (Celsia)

## 6.2.2 ASCII SLD

### 6.2.2 ASCII 单线图

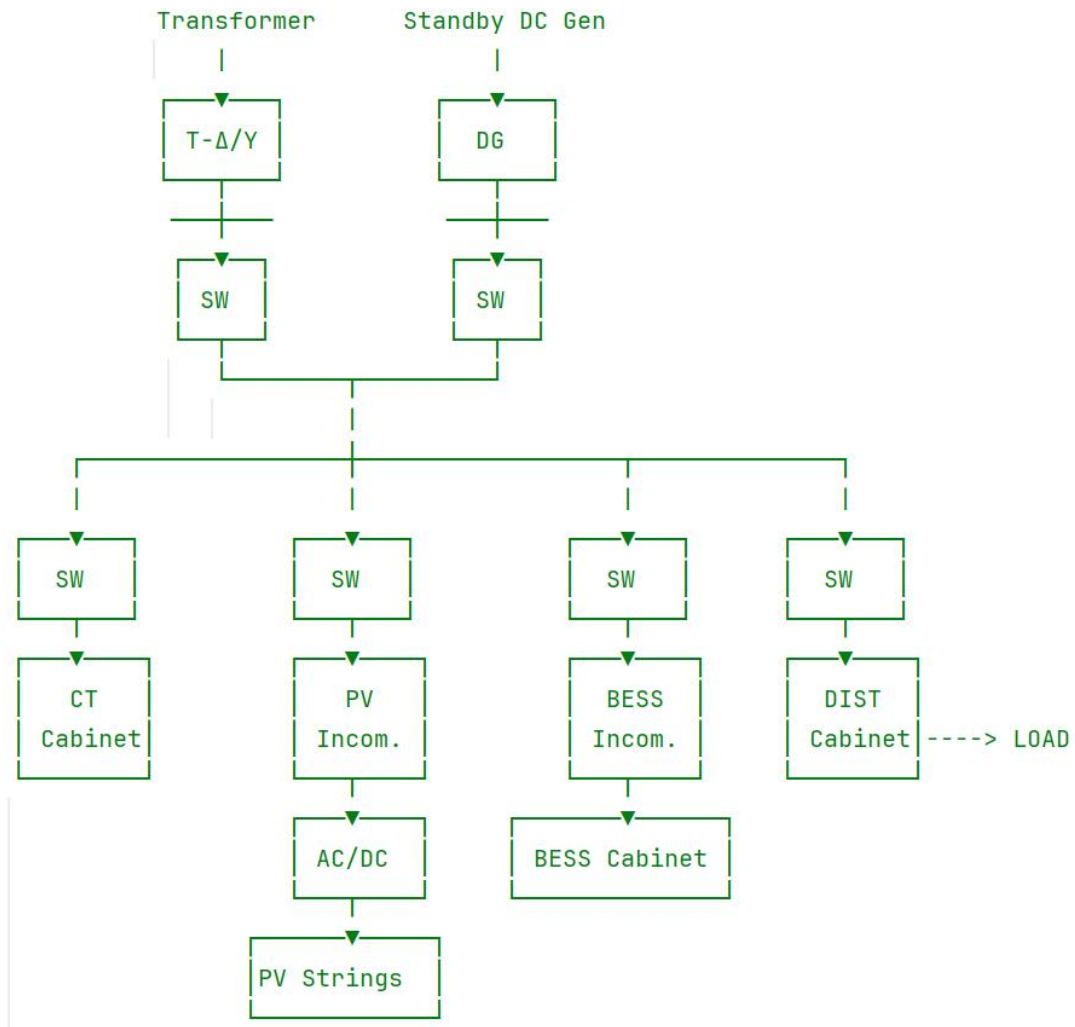

## 6.2.3 Technical Specifications

### 6.2.3 技术规格

#### Electrical Parameters (电气参数)

- PCS: 125 kW (GFL)
- Transformer: 400/480 Vac LV

- THD < 3%
- Response time < 20 ms
- Zero-export enforcement < 100 ms

#### **Control Parameters (控制参数)**

- PV priority for self-consumption
- Peak shaving
- TOU optimization
- Fast backup for critical loads

#### **Interconnection (并网要求)**

- Anti-islanding per IEC 62116
- Relay: UV/OV, UF/OF, ROCOF
- SCADA via Modbus TCP

### **6.3 Standard SLD Type 2 — Weak Grid PV+BESS (GFM Enabled)**

#### **6.3 弱电网标准单线图 (SLD 类型 2, 支持 GFM)**

##### **6.3.1 Applicable Regions**

##### **6.3.1 适用区域**

- Air-e (Atlántico, Magdalena, La Guajira)
- Afinia (Sucre, Córdoba, Cesar)
- All high-loss / unstable feeders

### 6.3.2 ASCII SLD

#### 6.3.2 ASCII 单线图

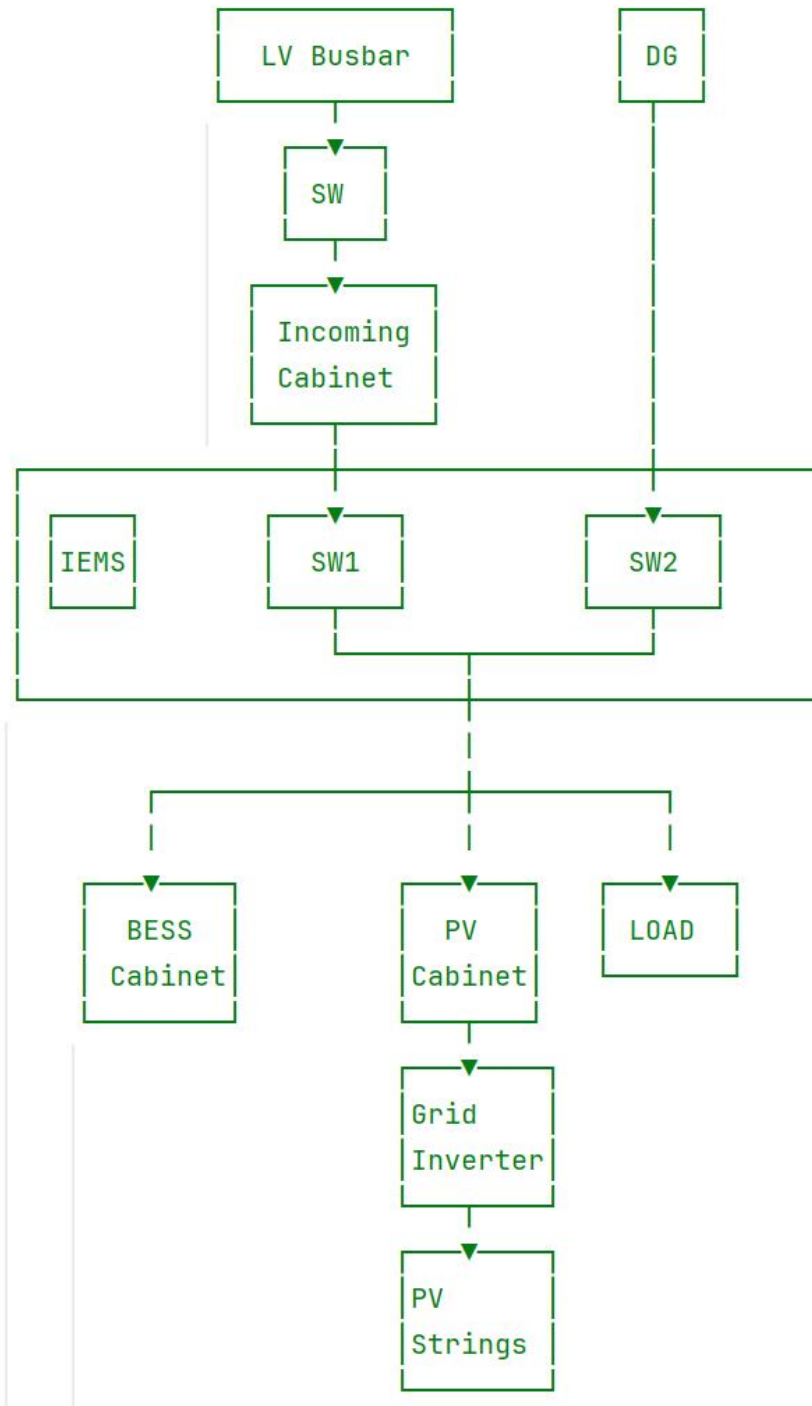

### 6.3.3 Technical Specifications

#### 6.3.3 技术规格

##### Electrical (电气参数)

- PCS supports full GFM mode
- LVRT/HVRT required
- Instantaneous islanding < 10 ms
- PQ stabilization active

##### Control (控制策略)

- GFM bus forming for weak grid
- Multi-PCS coordination via PowerSync
- Anti-tripping control during dips

##### Interconnection (并网要求)

- DERMS/SCADA compatibility
- Modbus/IEC104
- Protection: UV/OV, UF/OF, ROCOF

### 6.4 Standard SLD Type 3 — Off-grid / Hybrid Microgrid (ZNI)

#### 6.4 离网/混合微电网标准单线图 (SLD 类型 3)

##### 6.4.1 Applicable Regions

##### 6.4.1 适用区域

- Amazon
- Pacific jungle
- Rural ZNI villages
- Islands

## 6.4.2 ASCII SLD

### 6.4.2 ASCII 单线图

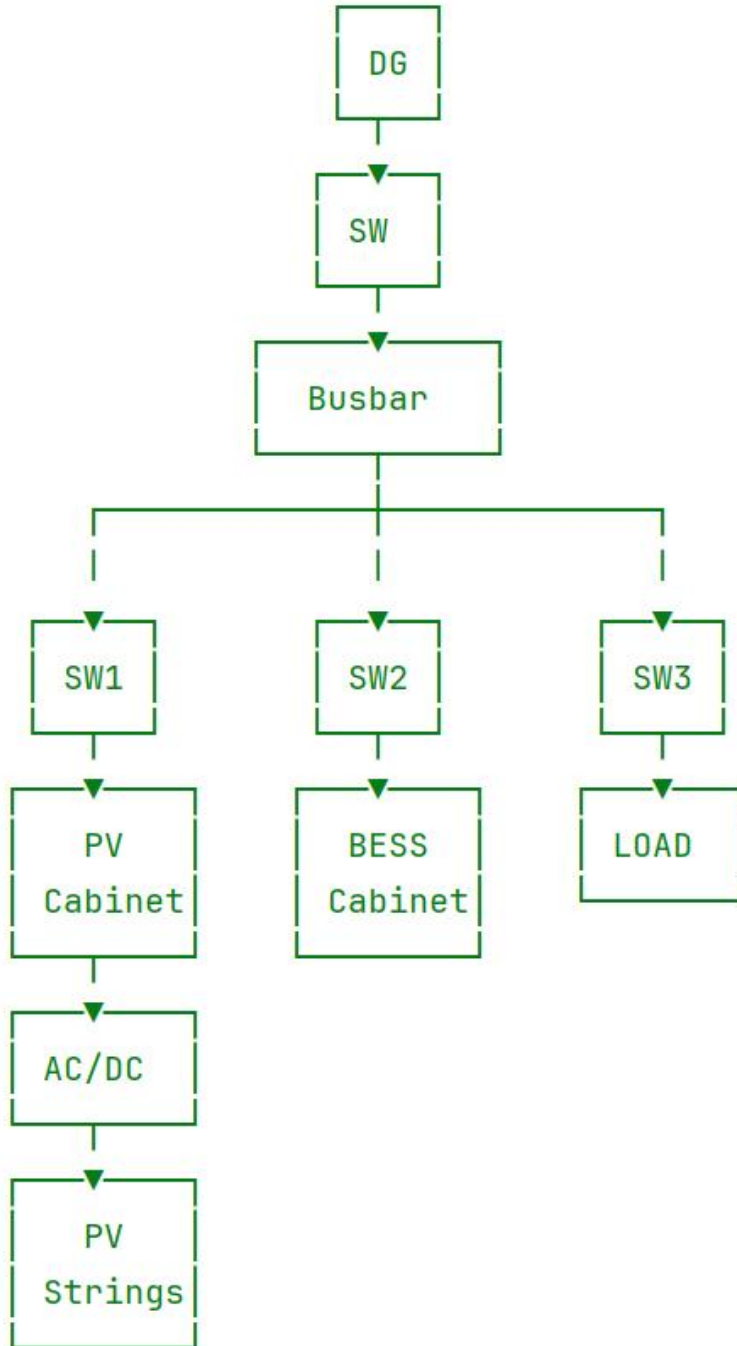

## 6.4.3 Technical Specifications

### 6.4.3 技术规格

#### Electrical (电气参数)

- PV oversizing allowed (1.2–1.8× load)
- BESS autonomy: 4–6 hours
- Diesel backup only
- Frequency stability via GFM PCS

#### Control (控制策略)

- PV–BESS–Diesel hybrid dispatch
- SOC-based scheduling
- Load shedding (L1/L2/L3)

#### Communications (通信)

- Modbus RTU/TCP
- EnergyOrbit for cloud monitoring

## 6.5 Protection Settings (RETIE + IEEE 1547)

### 6.5 并网保护定值 (RETIE + IEEE 1547)

#### 6.5.1 Standard Protection Table

#### 6.5.1 标准保护定值表

Protection	Trip Value	Delay	Standard	中文说明
OV1	110% Vnom	2.0 s	IEEE 1547	过压一级
OV2	120% Vnom	0.16 s	IEEE 1547	过压二级
UV1	88% Vnom	2.0 s	IEEE 1547	欠压一级
UV2	70% Vnom	0.16 s	IEEE 1547	欠压二级
OF1	60.5 Hz	0.16 s	IEEE 1547	过频一级
UF1	59.3 Hz	0.16 s	IEEE 1547	欠频一级
ROCOF	1.0 Hz/s	Instant	IEEE 1547	频率变化率
Anti-islanding	Active	–	IEC 62116	孤岛保护

## 6.6 SCADA & EMS Point Lists

### 6.6 SCADA / EMS 点表模板

#### 6.6.1 PCS Point List

#### 6.6.1 PCS 点表

No	Signal	Type	Unit	Description	中文说明
1	Active Power	AI	kW	PCS output	PCS 有功输出
2	Reactive Power	AI	kVar	PCS var	PCS 无功输出
3	SOC	AI	%	State of Charge	电量
4	SOH	AI	%	Health	健康度
5	Status	DI	-	Run/Stop/Fault	运行/停止/故障
6	Mode	DI	-	GFM/GFL	模式
7	Alarms	DI	-	Alarm Flag	告警

## 6.7 Communication Architecture

### 6.7 通信架构

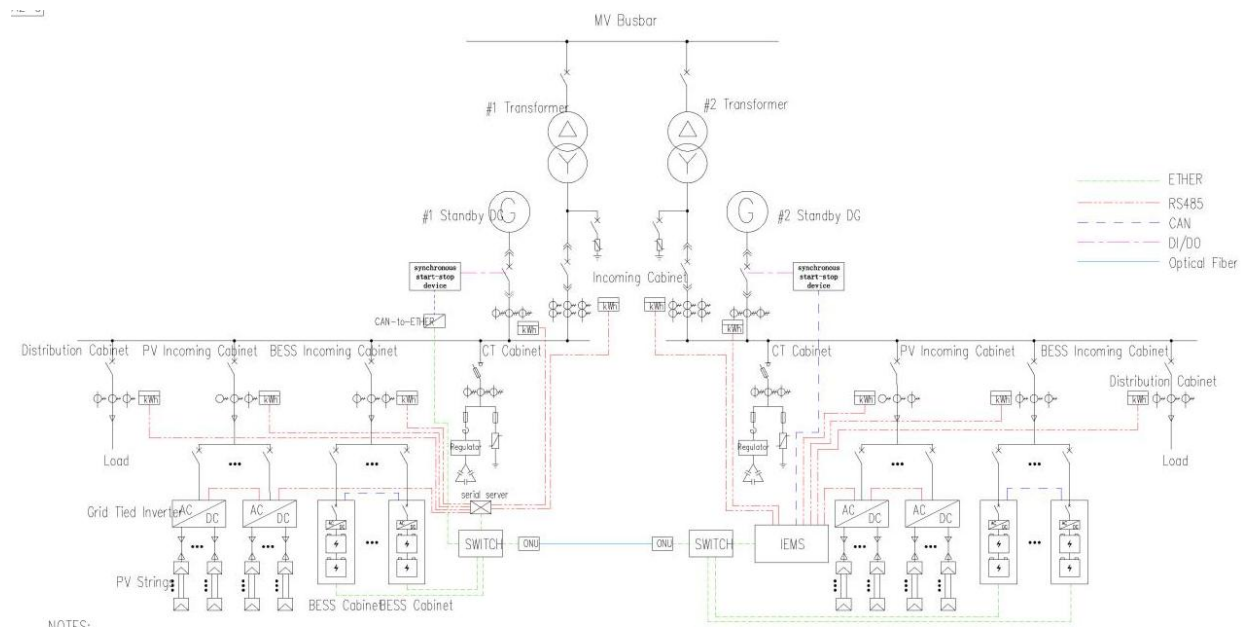

## 6.8 Typical BOM (Bill of Materials)

### 6.8 典型 BOM (物料清单)

Category	Description	中文说明
PV Modules	Tier-1 Mono	一级光伏组件
PV Inverters	100–150kW	光伏逆变器
BESS Cabinet	125kW/261kWh	柜式储能
PCS	GFL/GFM	PCS (成网/跟网)
PowerNest	PV+BESS controller	光储控制器
PowerSync	PCS cluster control	集群控制器
PowerPuls	Measurement	毫秒级量测
Switchgear	RMU/ATS/Breakers	配电设备
CT/VT	Protection/Measurement	互感器
Communication Cabinet	Switch, Router	通信柜

## Chapter 7 — Financial Modeling & IRR Analysis

### 第 7 章 —— 财务模型与 IRR 分析

#### 7.1 CREG Tariff Structure and PV+BESS Drivers

##### 7.1 CREG 电价结构与光储经济性驱动因素

Colombia' s C&I tariffs are among the highest in Latin America.

哥伦比亚工商业电价在拉美属于偏高水平。

##### Key economic drivers / 主要经济性驱动因素:

- High marginal energy prices (高边际电价 → 光伏自发自用经济性强)
- High demand charges (需量费高 → 储能削峰价值大)
- TOU opportunities (峰谷价差 → 储能套利空间)
- Weak-grid outages (弱电网停电频繁 → 储能备电价值)
- Diesel displacement in ZNI (ZNI 柴油成本昂贵 → 光储柴微电网 IRR 极高)

#### 7.2 CAPEX Structure

##### 7.2 CAPEX 成本结构

Typical system: PV 300–800 kWp + BESS 125 kW / 261 kWh

典型系统规模: 光伏 300–800 kWp + 125kW/261kWh 储能

Category	% of Total	中文说明
PV Modules	35–45%	光伏组件
PV Inverters	8–12%	光伏逆变器
BESS Hardware	22–28%	储能系统
PCS & controls	6–10%	PCS + 控制器
BOS materials	8–12%	电气安装材料
Installation	5–8%	施工安装
Engineering	2–4%	工程设计
Commissioning	1–2%	调试

## 7.3 OPEX Breakdown

### 7.3 OPEX 成本结构

OPEX 项目	年度成本	说明
PV O&M	1–1.5% of PV CAPEX	光伏运维
BESS O&M	2–3% of BESS CAPEX	储能运维
Cloud & communication	固定或变量费用	云服务与通信
Battery augmentation	第 7–10 年	电池扩容/替换

## 7.4 Revenue Streams for PV+BESS

### 7.4 光储的收益来源

#### (1) PV Self-consumption / 光伏自发自用节省

Savings: \$0.12–0.22 USD/kWh / 节省电费: \$0.12–0.22 USD/kWh

#### (2) Demand Charge Reduction/ 削峰

C&I demand charges = 20–40% of total bill / 需量费通常占企业总电费 20–40%

#### (3) TOU Arbitrage / 分时套利

Peak-off-peak spread: \$0.05–0.09 USD/kWh / 峰谷差价: \$0.05–0.09 USD/kWh

#### (4) Backup Value / 备电价值

Weak-grid (地区停电导致巨额隐性损失) → BESS (价值突出)

#### (5) Diesel Offset in ZNI / ZNI 柴油替代

Diesel cost: \$0.28–0.40 USD/kWh

Hybrid Microgrid → reduce 50–80% fuel cost.

## 7.5 Baseline IRR Model Example

### 7.5 基准 IRR 模型示例

**System:** PV 500 kWp + BESS 125kW/261kWh

**Region:** Bogotá (Enel)

## 10-year financial results / 十年财务结果:

指标	数值
年度净现金流	13.6–15.2 万美元
10 年 NPV	54–62 万美元
IRR	<b>13–18%</b>
Payback	4.5–6.0 年

## 7.6 IRR by Scenario

### 7.6 各场景的 IRR 范围

场景	IRR 范围	说明
稳定电网 (Enel/EPM/Celsia)	<b>12–18%</b>	光伏+削峰收益
弱电网 (Air-e/Afinia)	<b>14–22%</b>	PQ + 停电备电价值更高
ZNI 微电网	<b>20–35%</b>	柴油替代经济性极佳

## 7.7 Sensitivity Analysis

### 7.7 敏感性分析

#### Battery CAPEX Sensitivity / 电池成本敏感性

BESS CAPEX 变化	IRR 变化
+10%	-1.2%
-10%	+1.5%
-20%	+2.8%

#### Tariff Sensitivity / 电价敏感性

电价变化	IRR 变化
+10%	+1.8%
-10%	-1.6%

## 7.8 Business Models

### 7.8 商业模式

#### (1) EPC Turnkey (总包模式)

业主一次性采购 CAPEX。

#### (2) EaaS (Energy-as-a-Service) 能源服务模式

无 CAPEX; 按月付费; 适合弱电网客户。

#### (3) PPA / Opex 租赁模式

第三方投资, 合同期 10–15 年。

#### (4) Hybrid Microgrid-as-a-Service (ZNI)

政府/NGO 合作项目, 适用于偏远地区。

## 7.9 Summary

### 7.9 小结

Colombia provides one of the strongest financial cases for C&I PV+BESS in Latin America. IRR is attractive across all regions, especially in weak-grid and ZNI markets.

哥伦比亚是拉美工商业光储经济性最强的市场之一, 无论稳定电网、弱电网还是 ZNI 场景, IRR 都十分可观。

## Chapter 8 — Implementation Roadmap & EPC Workflow

### 第 8 章 —— 项目实施路线图与 EPC 交付流程

#### 8.1 Project Lifecycle Overview

##### 8.1 项目生命周期总览

A Colombia C&I PV+BESS project follows a 10-stage, end-to-end lifecycle, from initial survey to long-term operations. Each stage aligns with international EPC standards and local utility requirements (Enel, EPM, Celsia, Air-e, Afinia).

哥伦比亚工商业光储项目遵循 10 步完整生命周期，覆盖从现场勘查到长期运维的全过程，符合国际 EPC 标准及当地配电公司要求 (Enel、EPM、Celsia、Air-e、Afinia)。

##### Full Project Lifecycle (10 Steps) / 项目完整生命周期 (10 步)

1. Site Survey & Load Study / 现场勘查与负荷研究
2. Feasibility & ROI Analysis / 可研与投资回报测算
3. Preliminary Engineering (PE) / 初步设计 (PE)
4. Permitting & RETIE/CREG Filings / 许可与 RETIE/CREG 报批
5. Detailed Engineering (DE) / 施工图设计 (DE)
6. Procurement & FAT / 采购与工厂验收 (FAT)
7. Construction & Installation / 施工与安装
8. Commissioning & SAT / 调试与现场验收 (SAT)
9. Utility Interconnection / 配电公司并网
10. O&M & Digital Monitoring (EnergyOrbit) / 运维与数字化监控 (EnergyOrbit)

#### 8.2 Phase 1: Site Survey & Load Study

##### 8.2 阶段一：现场勘查与负荷研究

###### Goal:

Collect all technical inputs needed for engineering, financial modeling, and interconnection

design

目标：获取工程设计、财务测算、并网方案所需的全部数据。

**Outputs / 交付物:**

- Load profile (15/5/1-min resolution) / 负荷曲线 (15/5/1 分钟)
- Transformer details & capacity / 变压器参数与容量
- Feeder voltage fluctuation / 馈线电压波动
- Roof/ground structure / 屋顶/地面结构数据
- CREG tariff structure / CREG 电价结构

### 8.3 Phase 2: Feasibility & ROI Analysis

#### 8.3 阶段二: 可行性研究与 IRR 测算

This phase quantifies the economic viability of PV+BESS using local tariffs, load patterns, and CAPEX/OPEX assumptions.

该阶段基于当地电价、负荷曲线与 CAPEX/OPEX, 形成项目经济性测算。

**Outputs / 交付物:**

- Technical feasibility report / 技术可研报告
- Financial model (IRR、NPV、Payback) / 财务模型 (IRR、NPV、回收期)
- Recommended PV+BESS sizing / 推荐光储容量方案

### 8.4 Phase 3: Preliminary Engineering (PE)

#### 8.4 阶段三: 初步工程设计 (PE)

PE defines engineering fundamentals such as system architecture, SLD, PV/BESS sizing, and interconnection scheme.

初设阶段确定系统架构、单线图、光储容量与并网方案。

**Outputs / 交付物:**

- Preliminary SLD / 初步单线图
- System layout / 系统布局
- Protection concept / 保护方案框架
- Preliminary BOM / 初步 BOM

## 8.5 Phase 4: Permitting & RETIE/CREG Filings

### 8.5 阶段四: 许可与 RETIE/CREG 报批

All Colombian PV+BESS projects require RETIE compliance and CREG filings. Utilities conduct additional review depending on region.

哥伦比亚所有光储项目需满足 RETIE 安规及 CREG 并网报批，各配电公司另有特定审查流程。

#### Outputs / 交付物:

- RETIE compliance package / RETIE 合规文件
- CREG interconnection filing / CREG 并网申请
- Utility-specific documents (Enel/EPM 等) / 配电公司审查文件
- Environmental/municipal permits / 市政/环保许可

## 8.6 Phase 5: Detailed Engineering (DE)

### 8.6 阶段五: 施工图设计 (DE)

DE produces all drawings needed for construction and utility approval.

施工图设计阶段输出所有施工与并网所需技术文件。

#### Outputs / 交付物:

- Detailed SLD / 完整施工版单线图
- Cable schedule & routing / 电缆清单与敷设图
- Earthing & lightning protection / 接地与防雷设计
- SCADA/EMS communication design / SCADA/EMS 通信架构
- Protection relay setting sheet / 综合保护定值表
- Final BOM / 最终 BOM

## 8.7 Phase 6 — Procurement & FAT

### 8.7 阶段六 —— 采购与工厂验收 (FAT)

Procurement is executed in parallel with DE to minimize project duration. FAT ensures all equipment meets the required specifications.

采购与施工图设计可并行进行，FAT 确保设备满足项目技术要求。

#### FAT Tests / FAT 测试:

- PCS function test / PCS 功能测试
- Battery module test / 电池模组测试
- Communication test (Modbus/IEC104) / 通信测试 (Modbus/IEC104)
- Zero-export test / 零逆流测试
- GFM grid-forming test / GFM 成网测试

## 8.8 Phase 7: Construction & Installation

### 8.8 阶段七: 施工与安装

EPC construction covers mechanical mounting, electrical works, cabling, switchgear installation, and integration with existing infrastructure.

施工包括结构安装、电气敷设、开关柜安装及与现有系统的整合。

#### Tasks / 任务:

- PV installation (rooftop/ground) / 光伏安装 (屋顶/地面)
- BESS installation / 储能安装
- AC/DC cabling / AC/DC 电缆敷设
- Switchgear installation / 开关柜安装
- IT/communication deployment / 通信系统部署

## 8.9 Phase 8: Commissioning & SAT

### 8.9 阶段八: 调试与现场验收 (SAT)

SAT validates the system's performance, protection, and communication.

SAT 用于验证系统性能、保护策略与通信功能。

#### SAT Checklist / SAT 检查清单:

- PCS charge/discharge test / PCS 充放电测试
- PowerNest control test / PowerNest 控制逻辑测试
- PowerSync cluster operation / PowerSync 集群调度测试
- Zero-export test / 零逆流测试
- Anti-islanding test / 孤岛保护测试
- GFM stabilization test / GFM 稳定母线测试

## 8.10 Phase 9: Utility Interconnection

### 8.10 阶段九: 供电公司并网

All utilities require SAT documentation before granting final interconnection approval.

所有供电公司均要求 SAT 文件作为并网批准条件。

Outputs / 交付物:

- Relay test record / 保护测试报告
- As-built SLD / 竣工版单线图
- RETIE declaration / RETIE 合规声明
- Commissioning report / 调试报告

## 8.11 Phase 10: O&M & Digital Monitoring (EnergyOrbit)

### 8.11 阶段十: 运维与数字化监控 (EnergyOrbit)

EnergyOrbit provides 24/7 remote monitoring, predictive maintenance, and automated reporting for all sites.

## EnergyOrbit

提供 24/7 远程监控、预测性运维和自动化报表功能。

### Core O&M Functions / 核心运维功能:

- Real-time PV/BESS monitoring / 光伏/储能实时监控
- SOC/SOH tracking / SOC/SOH 追踪
- Event/alarm management / 告警与事件管理
- Performance KPI dashboard / 性能 KPI 仪表盘
- Carbon reporting / 碳排放报表
- Predictive maintenance / 预测性维护

## 8.12 Implementation Timeline

### 8.12 项目实施周期

Typical project duration: 6–9 months / 典型项目周期: 6–9 个月

Phase	Duration	中文说明
Survey + Feasibility	2–4 weeks	勘查 + 可研
PE Design	2–3 weeks	初设
Permitting	1–2 months	许可
Detailed Engineering	3–5 weeks	施工图
Procurement & FAT	1–2 months	采购 + FAT
Construction	1–2 months	施工
SAT + Interconnection	2–4 weeks	调试 + 并网

## 8.13 Summary

### 8.13 小结

This chapter provides a complete, EPC-ready roadmap enabling smooth deployment of PV+BESS systems across Colombia. It aligns with RETIE/CREG regulations and utility interconnection practices, ensuring predictable project execution.

本章提供了可直接用于 EPC 实施的完整路线图，与 RETIE/CREG 规范及配电公司流程完全对齐，确保光储项目在哥伦比亚顺利落地、按期交付。

## Chapter 9 — Risk Assessment & Mitigation Plan

### 第 9 章 —— 风险评估与缓解方案

本章节使用国际 EPC、金融机构 (IFC/IDB)、以及哥伦比亚配电公司 (Enel / EPM / Celsia / Air-e / Afinia) 普遍采用的六大类风险框架。

#### 9.1 Overview of Risk Categories

##### 9.1 风险类别总览

A C&I PV+BESS project in Colombia faces six major categories of risks.

哥伦比亚工商业光储项目主要面临以下六大风险类别：

- Regulatory & Interconnection Risks 法规与并网风险
- Grid & Technical Risks 电网与技术风险
- Construction & EPC Execution Risks 施工与 EPC 执行风险
- Financial & Tariff Risks 财务与电价风险
- Environmental & Climate Risks 环境与气候风险
- O&M & Lifecycle Risks 运维与生命周期风险

#### 9.2 Regulatory & Interconnection Risks

##### 9.2 法规与并网风险

**Risk 1: Utility Interconnection Delays / 风险 1: 配电公司并网审核延迟**

**Mitigation / 缓解:**

- Standardized RETIE/CREG filing packages / 使用标准化 RETIE/CREG 报批文件包
- Utility-specific SLD / Protection settings / 提供针对 Enel/EPM/Celsia/Air-e/Afinia 的专用 SLD 与保护定值
- Submit documents early during PE phase / 在初设阶段即提前提交资料

**Risk 2: Changes in CREG or Ministry of Energy regulations / 风险 2: CREG 或能源部政策变**

**动**

**Mitigation / 缓解:**

- EnergyOrbit includes regulatory update tracking / nergyOrbit 云平台自动跟踪政策更新
- Flexible EMS algorithms allow operational adjustments / EMS 可快速调整策略应对新规则

**Risk 3: Zero-export compliance violations / 风险 3: 零逆流执行不严格导致不合规**

**Mitigation / 缓解:**

- PowerPuls 1–10ms high-speed sensing / PowerPuls 毫秒级量测
- PowerNest fast-loop zero-export (<100ms) / PowerNest 快速闭环零逆流控制
- Dual CT/VT verification / CT/VT 双重校验

## 9.3 Grid & Technical Risks

### 9.3 电网与技术风险

**Risk 4: Weak-grid instability / 风险 4: 弱电网不稳定**

**Mitigation / 缓解:**

- Use GFM-enabled PCS / 使用支持 GFM 的 PCS
- PowerSync coordinates multi-PCS / 由 PowerSync 协同多台 PCS 稳定母线
- Enable LVRT/HVRT / 启用低/高电压穿越功能

**Risk 5: Voltage dips causing PV trips / 风险 5: 电压跌落导致光伏脱网**

**Mitigation / 缓解:**

- PQ sensors + PowerPuls
- Re-tuning inverter ride-through settings
- PowerNest voltage stabilization

**Risk 6: Transformer overload / 风险 6: 变压器过载**

**Mitigation / 缓解:**

- PowerHub 控制快充负荷

- PowerNest 限制光储输出功率
- EMS 动态功率分配

### **Risk 7: Cybersecurity threats / 风险 7: 网络安全风险**

#### **Mitigation / 缓解:**

- IEC 62443-ready controller design / 控制器满足 IEC 62443 网络安全框架
- Encrypted MQTT / VPN / MQTT 加密或专线
- Role-based access control / EMS 分角色权限控制

## **9.4 Construction & EPC Execution Risks**

### **9.4 施工与 EPC 执行风险**

#### **Risk 8: Permitting delays / 风险 8: 市政或主管部门审批延迟**

##### **Mitigation / 缓解:**

Start permitting in parallel with PE; pre-align with authorities / 许可与初设同步推进，提前与主管部门沟通。

#### **Risk 9: Material delays / 风险 9: 物料供应延迟**

##### **Mitigation / 缓解:**

early ordering of long-lead items (PCS, BESS, RMU). / 关键物料 (PCS/BESS/RMU) 提前下单，必要时双供应链。

#### **Risk 10: EPC workmanship issues / 风险 10: 施工质量不稳定**

##### **Mitigation / 缓解:**

Use LIVOLTEK-certified EPC partners + mandatory SAT / 采用 LIVOLTEK 认证 EPC，并由总部技术团队执行 SAT 验收。

## 9.5 Financial & Tariff Risks

### 9.5 财务与电价风险

**Risk 11: Tariff fluctuation under CREG / 风险 11: CREG 电价波动**

**Mitigation / 缓解:**

- IRR buffer > 12% / IRR 预留 ≥12% 安全垫
- EnergyOrbit tariff auto-update / EnergyOrbit 自动更新电价模型

**Risk 12: USD/COP currency risk / 风险 12: 汇率风险**

**Mitigation / 缓解:**

- Partial hedging / 局部套期保值
- USD-indexed PPA contracts / 使用美元计价或部分美元化合同

**Risk 13: Fast battery cost reductions affecting PPA contracts / 风险 13: 电池成本快速下降导致 PPA 模式风险**

**Mitigation / 缓解:**

- 采用 5-7 年短期 EaaS 模式
- 模块化可替换电池系统

## 9.6 Environmental & Climate Risks

### 9.6 环境与气候风险

**Risk 14: High temperature degrading battery life / 风险 14: 高温导致电池衰减**

**Mitigation / 缓解:**

- Thermal-controlled BESS / 恒温型 BESS 系统
- SOC/SOH monitoring / SOC/SOH 实时监控

**Risk 15: Coastal humidity & corrosion / 风险 15: 沿海高湿高腐蚀**

**Mitigation / 缓解:**

- C5 anti-corrosion enclosure / C5 等级防腐箱体
- PCB conformal coating / PCB 三防喷涂

## 9.7 O&M & Lifecycle Risks

### 9.7 运维与全生命周期风险

#### Risk 16: Insufficient monitoring / 风险 16: 监控不足

##### Mitigation / 缓解:

EnergyOrbit 24/7 monitoring + automated ticketing / EnergyOrbit 24/7 全时监控 + 自动工单系统。

#### Risk 17: Battery degradation / 风险 17: 电池衰减

##### Mitigation / 缓解:

- Annual SOH calibration / 每年 SOH 校准
- PowerSync cell-balancing / PowerSync 电芯均衡
- Optional battery augmentation / 电池扩容机制

#### Risk 18: Spare parts availability / 风险 18: 备件不足

##### Mitigation / 缓解:

- Bogotá/Medellín spare parts hub / 波哥大 / 麦德林 建立备件中心
- Local service partners / 建立本地化服务体系

## 9.8 Risk Matrix Summary

### 9.8 风险矩阵总结

风险类型	严重性	可控性	说明
法规 & 并网	中	强	可通过标准文件包缓解
电网	高 (沿海)	强	GFM/PQ 技术可显著降低风险
EPC	中	中-强	依赖合作伙伴体系
财务	中	中	电价和汇率有波动性
环境	中-高	强	温控+防腐可有效控制
运维	中	强	数字运维可最大化可控性

## 9.9 Summary

### 9.9 小结

LIVOLTEK's digital ecosystem significantly reduces all six major risk categories through real-time measurement (PowerPuls), integrated control (PowerNest), PCS coordination (PowerSync), EMS optimization (PowerHive), and cloud intelligence (EnergyOrbit).

通过 PowerPuls 毫秒级量测、PowerNest 一体化控制、PowerSync PCS 协同、PowerHive 园区 EMS 及 EnergyOrbit 云智能平台，六大类风险均可显著降低。

The combined effect enables stable, predictable, bankable PV+BESS projects throughout Colombia.

整体效果确保光储项目在哥伦比亚具备稳定性、可预测性与可融资性。

## Chapter 10 — Appendices (Technical Annex)

### 第 10 章 —— 附录 (技术附件)

#### 10.1 Technical Datasheet Summaries

#### 10.1 技术规格书摘要

##### 10.1.1 BESS Cabinet (125 kW / 261 kWh) — Datasheet

##### 10.1.1 柜式储能 (125kW / 261kWh) —— 技术规格

###### Electrical (电气参数)

- Rated Power: 125 kW (功率: 125 kW)
- Rated Energy: 261 kWh (容量: 261 kWh)
- Voltage: 400V / 480V AC (输出电压: 400V / 480V)
- PCS Mode: GFL + GFM (PCS 模式: GFL + GFM)
- THD < 3% (谐波 THD < 3%)
- Response < 20 ms (响应时间 < 20 ms)

##### 10.1.2 PowerNest — PV+BESS Integrated Controller

##### 10.1.2 PowerNest —— 光储一体化控制器

###### Features / 特性:

- Zero Export (<100 ms) / 零逆流控制 <100ms
- Islanding <10 ms / 并离网切换 <10ms
- PV-BESS coordinated control / 光储协调控制
- Peak shaving / TOU optimization / 削峰 / 分时优化

##### 10.1.3 PowerSync — PCS Cluster Controller

##### 10.1.3 PowerSync —— PCS 集群控制器

###### Features / 特性:

- Multi-PCS sync / 多 PCS 协同
- GFM forming / 成网 (GFM)
- Ramp-rate control / 爬坡率控制
- Black-start / 黑启动

### **10.1.4 PowerPuls — High-speed Measurement Module**

#### **10.1.4 PowerPuls —— 毫秒级量测模组**

**Features / 特性:**

- 1–10 ms sampling / 毫秒级采样
- Reverse power detection / 逆功率检测
- PQ sensing / PQ 量测
- Feeder monitoring / 馈线监测

### **10.1.5 PowerHive & EnergyOrbit**

#### **10.1.5 PowerHive 与 EnergyOrbit**

**Features / 特性:**

- Park-level EMS / 园区 EMS
- Cloud-based fleet monitoring / 云端集群监控
- Carbon accounting / 碳排管理
- Predictive O&M / 预测性维护

## **10.2 Standard SLDs**

### **10.2 标准单线图**

#### **10.2.1 SLD Type A — Stable Grid**

#### **10.2.2 SLD Type B — Weak Grid (GFM)**

#### **10.2.3 SLD Type C — Off-grid Hybrid Microgrid**

## 10.3 Protection Setting Template

### 10.3 并网保护定值模板

保护功能	定值	延时	标准	中文说明
OV1	110% Vnom	2.0 s	IEEE 1547	过压一级
UV2	70% Vnom	0.16 s	IEEE 1547	欠压二级
OF1	60.5 Hz	0.16 s	IEEE 1547	过频一级
UF1	59.3 Hz	0.16 s	IEEE 1547	欠频一级
ROCOF	1.0 Hz/s	Instant	IEEE 1547	频率变化率
Anti-Islanding	Active	-	IEC 62116	孤岛保护

## 10.4 SCADA / EMS Point List Templates

### 10.4 SCADA / EMS 点表模板

#### PCS 点表 (示例)

No	Signal	Type	Description	中文说明
1	Active Power	AI	PCS output	有功功率
2	Reactive Power	AI	PCS VAR	无功功率
3	SOC	AI	Battery SOC	电池电量
4	SOH	AI	Battery SOH	电池健康度
5	Mode	DI	GFM/GFL	模式
6	Alarm	DI	Fault alarm	故障告警

## 10.5 Communication Architecture Diagram

### 10.5 通信架构

## 10.6 Typical BOM (Bill of Materials)

### 10.6 典型物料清单

类别	描述
光伏组件	Tier-1 单晶组件
光伏逆变器	100-150 kW
储能系统	125kW/261kWh 柜式; 5MWh 集装箱

PCS	支持 GFM/GFL
PowerNest	光储控制器
PowerSync	PCS 集群控制器
PowerPuls	毫秒级量测模块
Switchgear	RMU、ATS、AC 开关
CT/VT	计量/保护互感器
通信设备	Switch、Router

## 10.7 SAT & Commissioning Checklists

### 10.7 SAT & 调试清单

#### BESS SAT

- 充放电测试
- PCS 功能测试
- BMS 通信验证
- 零逆流测试
- 成网 (GFM) 测试
- 温控系统测试

#### PV SAT

- 极性测试
- 绝缘测试
- MPPT 测试
- 逆变器通信

## 10.8 O&M Templates

### 10.8 运维模板

#### 月度运维报告 (示例)

- PV 发电量 (月累计)
- BESS 循环次数 & SOH
- 事件 & 告警记录

- 性能 KPI
- 碳排报表

### 故障排查矩阵 (示例)

问题	原因	解决措施
光伏低发电量	遮挡	清除遮挡
储能不充电	PCS 故障	重启/检修
逆流控制失败	CT 接反	调整 CT 接线

## 10.9 Compliance Matrix

### 10.9 合规性矩阵

规范	系统组成	说明
RETIE	配电、电缆、安规	哥伦比亚必选
CREG	并网流程	电监局要求
IEC 62116	孤岛检测	适用于 PCS
IEC 61000	电磁兼容	EMC 要求
IEEE 1547	并网性能	PCS 并网行为
IEC 62443	网络安全	控制器/EMS

## 10.10 Deliverable Package List

### 10.10 最终交付文件清单

#### 技术文件:

- SLD (3 个版本)
- 施工图 (DE 全套)
- Datasheets (所有设备)
- 保护定值表
- 点表
- 通信架构
- BOM (详细版)

#### 法规文件:

- RETIE 合规

- CREG 并网申请
- 配电公司专用报批文件

**EPC 文件:**

- SAT 调试报告
- QA/QC 报告
- As-built 竣工图
- 运维手册

## Conclusion

### 结语

This document is designed to be a complete, end-to-end framework for deploying C&I PV+BESS solutions across Colombia. It integrates market insights, regulatory understanding, engineering best practices, technical architecture, digital ecosystem capabilities, financial modeling, EPC workflow, and risk mitigation.

本文件旨在为哥伦比亚工商业光储的落地提供一套完整的一体化体系，涵盖市场洞察、法规理解、工程最佳实践、数字能源生态、财务测算、EPC 执行与风险防控等全部关键环节。

With LIVOLTEK' s full-stack capabilities—PowerPuls, PowerNest, PowerSync, PowerHub, PowerHive, EnergyOrbit, and world-class BESS products—customers and EPC partners gain a comprehensive pathway to build reliable, scalable, future-proof distributed energy infrastructure in Colombia.

依托 LIVOLTEK 全栈能力 (PowerPuls、PowerNest、PowerSync、PowerHub、PowerHive、EnergyOrbit 以及高可靠储能产品)，客户与 EPC 可在哥伦比亚快速部署高可靠、可扩展、未来可持续的分布式能源系统。

This is not just a product offering—it is a complete ecosystem.

这不仅是一套产品，更是一整套生态体系。